

CODIGO	'A'	'B'	SECCION DEL CONDUCTOR (MM <sup>2</sup> )	MATERIAL	OBSERVACIONES
11029xx084 (29.084)	0.75	1.25	1.30 / 4.20	LATON	
11029xx085 (29.085)	0.75	1.25	1.30 / 4.20	B. FOSFO.	
11029xx473 (29473)	0.50	1.10	1.30 / 4.20	LATON	

7  
8  
7

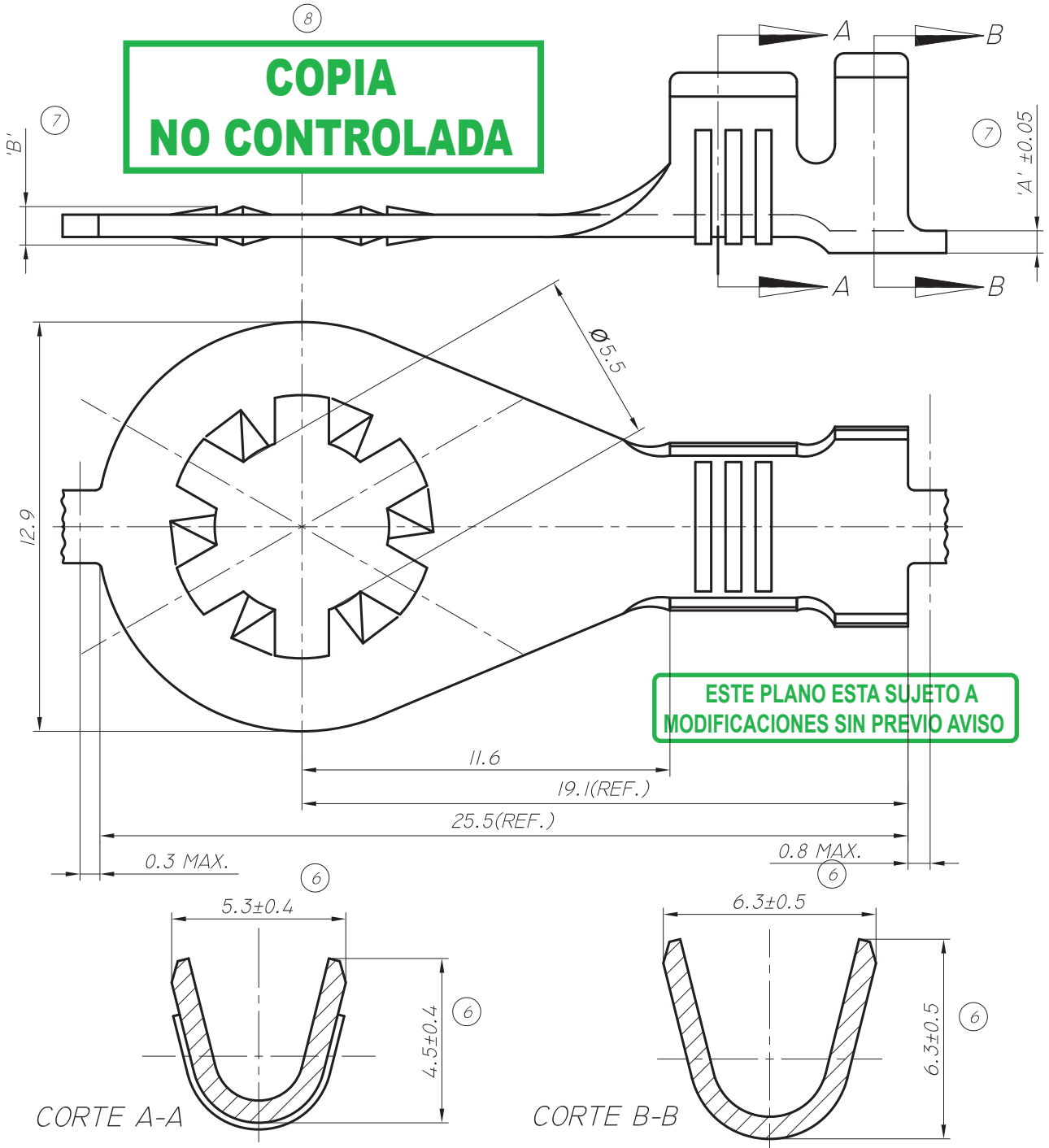

23.08.11	8	1.10 ERA 1.20		G.G.		
31.01.11	7	SE AGREGA CODIGO 29473 Y COTA 'A' Y 'B'.		L.L.	O.A.C.	GARCIA
13.06.05	6	TOLERANCIA ERA ±0.15		L.L.	O.A.C.	GARCIA
FECHA	Nº	MODIFICACIONES		DIBUJO	REVISO	APROBO



INDUSTRIAS ZETA S.R.L.

TOLERANCIA NO ACOTADA:

LINEAL: ±0.15

ANGULAR: ± 1° 30'

MATERIAL: VER TABLA	ESCALA: 5:1	DIBUJO	REVISO	APROBO
CODIGO MAS: /E = TERMINACION ESTAÑADA /N = TERMINACION NIQUELADA /P = TERMINACION PLATEADA /S = PIEZA SUELTA	HOJA: 1 DE 1	P.S.	O.A.C.	GARCIA
		13.10.00	13.10.00	13.10.00
DENOMINACION: TERMINAL CONTACTO OJAL DE SEGURIDAD Ø 5.40 MM			PLANO PARA CLIENTE Nº:	29000