

CODIGO	A	SECCION DEL CONDUCTOR	OBSERVACIONES
11036xx126 (36.126)	5.3	0.30/0.80	
11036xx329 (36.329)	7.7	0.30/0.80	

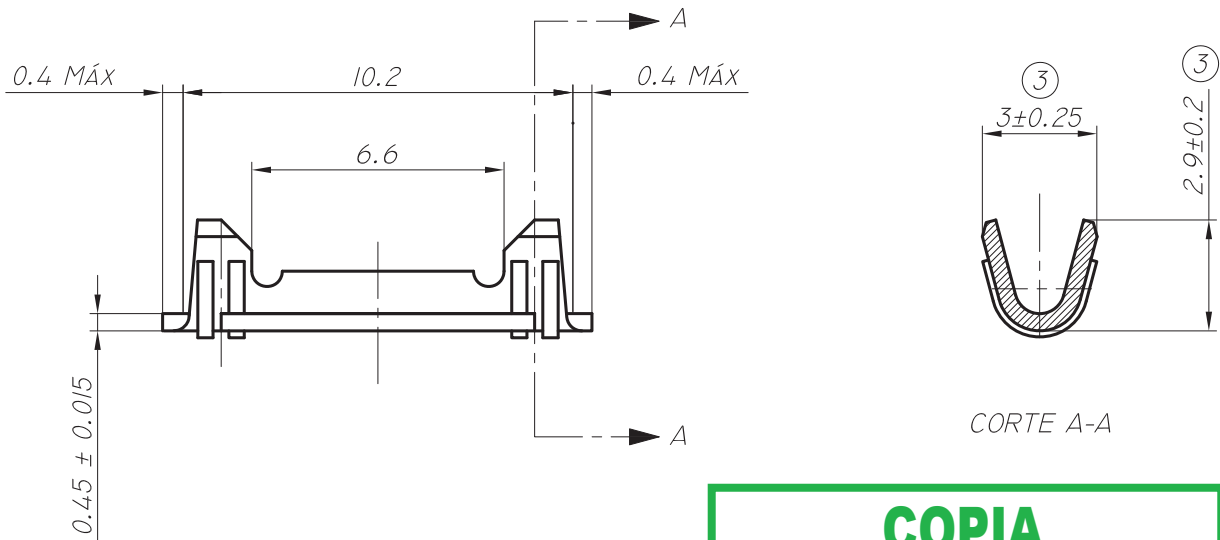

20.07.05	3	TOLERANCIA COTA 3.0 ERA $\pm 0.2$ Y TOL. COTA 2.9 ERA $\pm 0.15$	L.L.	O.A.C.	GARCIA
25.08.04	2	NUEVA VERSION EN CAD.	L.M.	O.A.C.	GARCIA
FECHA	Nº	MODIFICACIONES	DIBUJO	REVISO	APROBO



INDUSTRIAS ZETA S.R.L.

TOLERANCIA NO ACOTADA:

LINEAL:  $\pm 0.15$

ANGULAR:  $\pm 1^\circ 30'$

MATERIAL: LATON	ESCALA: 4 : 1	DIBUJO	REVISO	APROBO
CODIGO MAS: /E = TERMINACION ESTAÑADA /N = TERMINACION NIQUELADA /P = TERMINACION PLATEADA /S = PIEZA SUELTA	HOJA 2 DE 2	L.M.	O.A.C.	GARCIA
		25.08.04	25.08.04	25.08.04
DENOMINACION: TERMINAL OJAL BANDERA.			PLANO PARA CLIENTE N°:	36000