

CODIGO	MATERIAL	E	F. INS. [Kg]	F. 10° EXT. [Kg]	OBSERVACIONES
11058xx216 (58.216)	LATON	0.45	≤ 8.0	2.0 / 7.0	
11058xx383 (58.383)	ACERO INOX.	0.40	≤ 8.0	2.0 / 7.0	

5

10

9

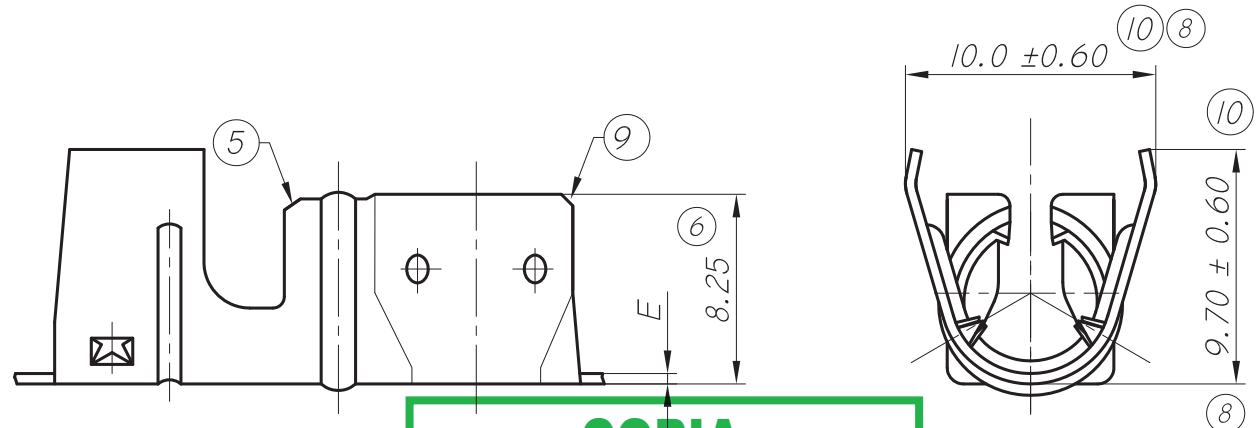

**COPIA
NO CONTROLADA**

9

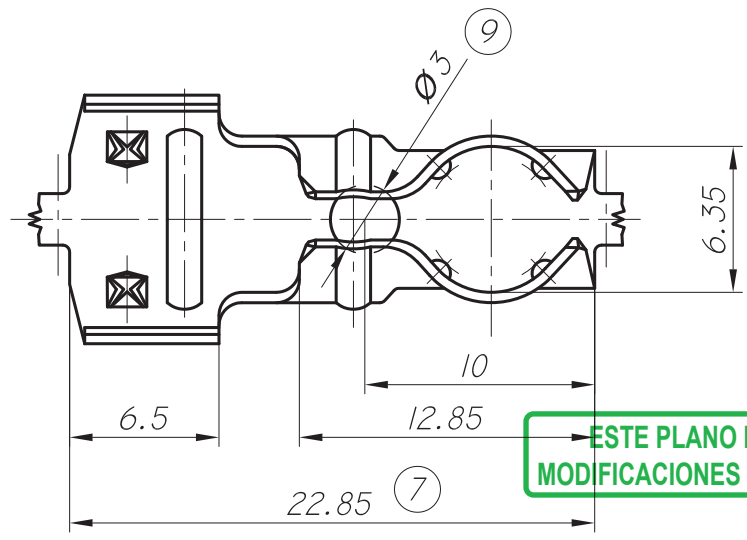

**ESTE PLANO ESTA SUJETO A
MODIFICACIONES SIN PREVIO AVISO**

12.04.10	10	COTA 10.0 ERA 10.20 Y 9.70 ERA 10.0.	L.L.		
09.03.10	9	ESCALA ERA 3:1 Y SE AGREGA AGUJ. Ø3 Y PESTAÑAS.	L.L.	O.A.C.	GARCIA
10.06.05	8	TOLERANCIA ERA ± 0.30	L.L.	O.A.C.	GARCIA
19.01.04	7	ERA 23 ± 0.15.	P.S.	O.A.C.	GARCIA
19.11.02	6	ALTURA DEL CUERPO ERA 8.0 ± 0.15.	P.S.	O.A.C.	GARCIA
11.10.02	5	NUEVA EMISION REEMPLAZA A PLANO FECHA 29.02.96 SE AGREGA PESTAÑA Y PIEZA 58383.	P.S.	O.A.C.	GARCIA

FECHA	Nº	MODIFICACIONES	DIBUJO	REVISO	APROBO
-------	----	----------------	--------	--------	--------



INDUSTRIAS ZETA S.R.L.

TOLERANCIA NO ACOTADA:
LINEAL: ±0.15
ANGULAR: ± 1° 30'

MATERIAL: VER TABLA	ESCALA: 3:1	DIBUJO	REVISO	APROBO
CODIGO MAS: /E = TERMINACION ESTAÑADA /N = TERMINACION NIQUELADA /P = TERMINACION PLATEADA /S = PIEZA SUELTA	HOJA: 1 DE 1	P.S.	O.A.C.	GARCIA
		11.10.02	11.10.02	11.10.02

DENOMINACION: TERMINAL CONTACTO BUJIA A 90°

PLANO PARA
CLIENTE Nº: 58000