

CODIGO	DESCRIPCION	CLIP	INSERCIÓN [Kg]	10ª EXT. [Kg]
11061xx459 (61.459)	CONJUNTO	2-87419	≤ 8.0	2.0 / 7.0
11061xx474 (61.474)	CONJUNTO	2-87475	4.0/6.0	4.0 / 8.0

1

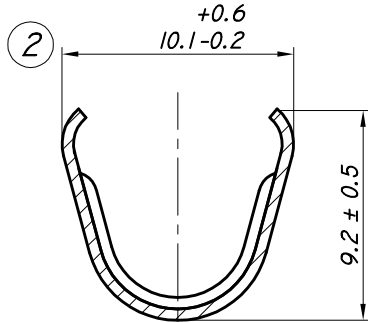

CORTE A-A

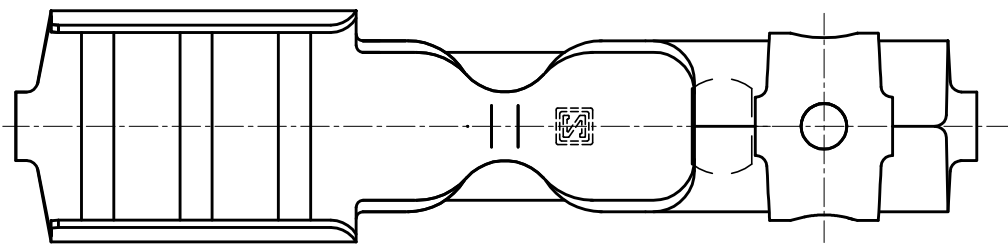
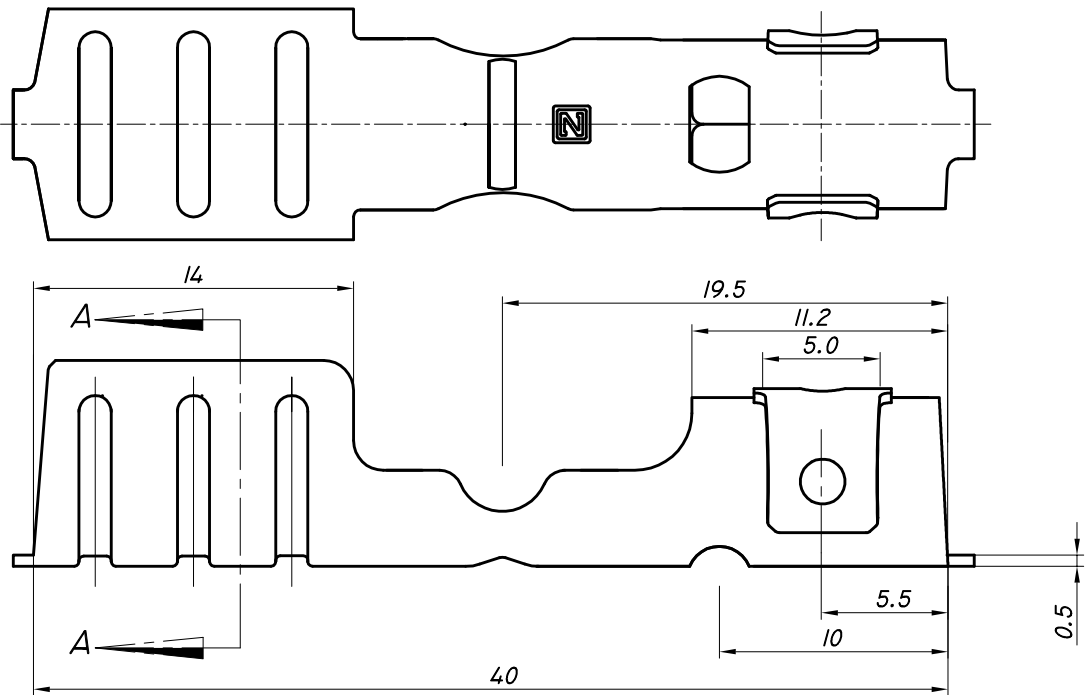
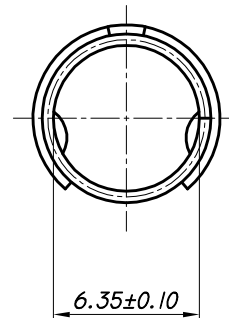

2

13.11.18	2	TOLERANCIA DE COTA ERA ±0.5.	L.L.		
18.01.13	1	SE AGREGA PIEZA 61474	G.G.		
FECHA	Nº	MODIFICACIONES	DIBUJO	REVISO	APROBO



INDUSTRIAS ZETA S.R.L.

TOLERANCIA NO ACOTADA:
LINEAL: ±0.2
ANGULAR: ± 1° 30'

MATERIAL: AC INOX.	ESCALA: 3:1	NOMBRE	REVISO	APROBO
CODIGO MAS: /E = TERMINACION ESTAÑADA /N = TERMINACION NIQUELADA /P = TERMINACION PLATEADA /S = PIEZA SUELTA	HOJA: 1 DE 1	L.L.		
		07.09.10		

DENOMINACION: TERMINAL BUJIA PLEGABLE	PLANO PARA CLIENTE Nº: 61000
---------------------------------------	------------------------------