

CODIGO	MATERIAL	F. EXTRACCION [Kg]	OBSERVACIONES
11084.xx389 (84.389)	BRONCE FOSFOROSO	≥ 14.0	
11084.xx392 (84.392)	LATON	≥ 14.0	

ESTE PLANO ESTA SUJETO A MODIFICACIONES SIN PREVIO AVISO

③

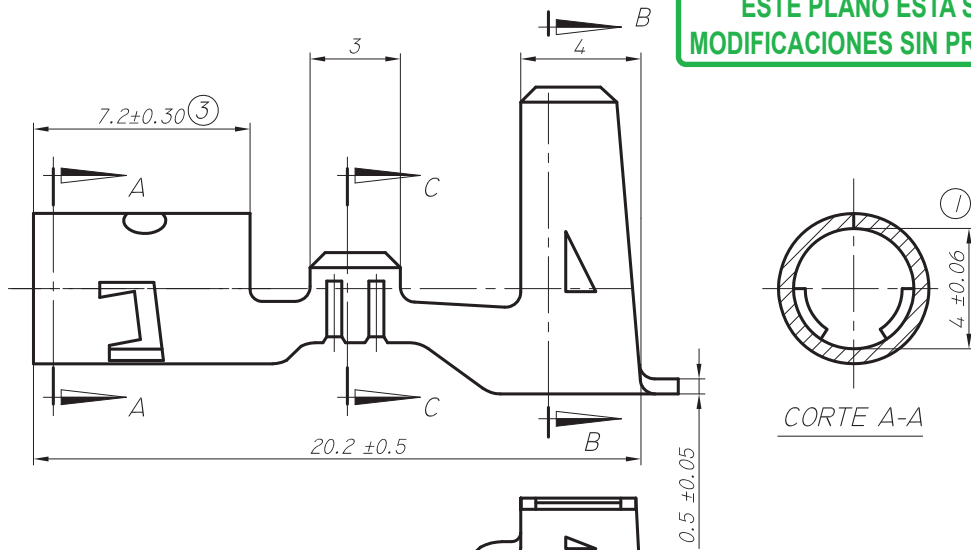

CORTE A-A

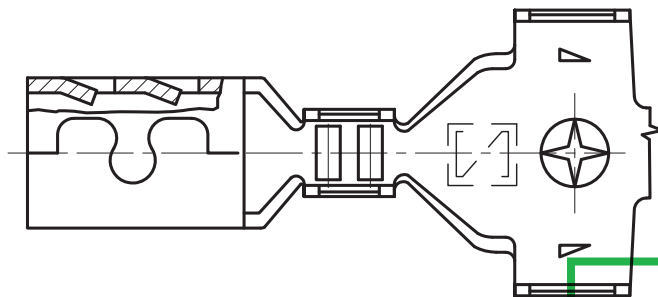

COPIA NO CONTROLADA

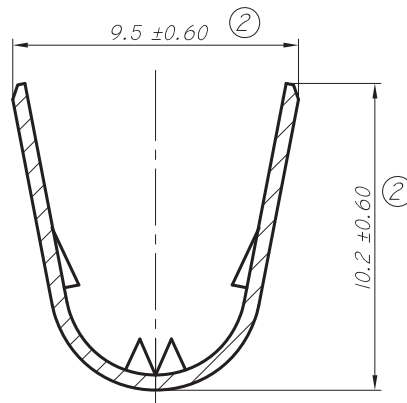

CORTE B-B

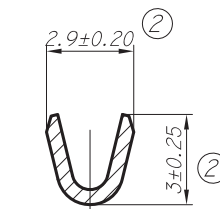

CORTE C-C

17.01.08	3	SE MODIFICA TOLERANCIA DE COTA, ERA ±0.15.	L.L.		
10.06.05	2	TOLERANCIA ERA ±0.30 EXCEPTO COTA 2.9 Y 3 ERA ±0.15	L.L.	O.A.C.	GARCIA
25.11.03	1	ERA 4 ± 0.15.	P.S.	O.A.C.	GARCIA
FECHA	Nº	MODIFICACIONES	DIBUJO	REVISO	APROBO



INDUSTRIAS ZETA S.R.L.

TOLERANCIA NO ACOTADA:

LINEAL: ±0.15

ANGULAR: ± 1° 30'

MATERIAL: VER TABLA	ESCALA: 5:1	DIBUJO	REVISO	APROBO
CODIGO MAS: /E = TERMINACION ESTAÑADA /N = TERMINACION NIQUELADA /P = TERMINACION PLATEADA /S = PIEZA SUELTA	HOJA: 1 DE 1	P.S.	O.A.C.	GARCIA
		29.09.03	29.09.03	29.09.03

DENOMINACION: TERMINAL ENCENDIDO

PLANO PARA CLIENTE N°: 84000